

KFC-1671

SERVICE MANUAL

KENWOOD

© 1986-12 PRINTED IN JAPAN
B51-3107-00 (G) 2015

EXTERNAL VIEW

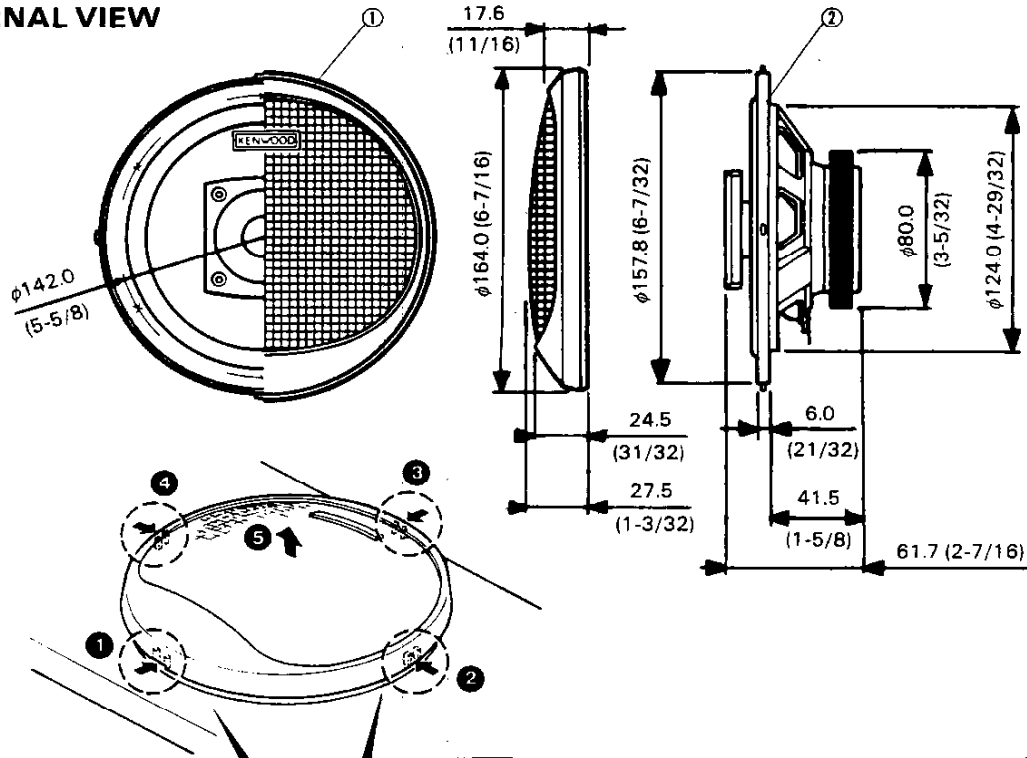

Unit: mm (inch)

To remove the front grille, pry out the cut off portions ① to ④ with a (-) screwdriver in turn as shown in the left figure.

PARTS LIST

* New Parts

Parts without Parts No. are not supplied.

Les articles non mentionnes dans le Parts No. ne sont pas fournis.

Teile ohne Parts No. werden nicht geliefert.

SPECIFICATIONS

Speakers

Woofers _____ 170g (6 oz) Magnet
16cm (6") Water-resistant cone

Tweeters _____ 50mm (2") cone

Peak power _____ 90 watts

Sensitivity _____ 90 dB/w at 1m

Impedance _____ 4 ohms

Insulated cable _____ 4.5m (14.7ft) 2 pcs

Weight per speaker with grille _____ 800 g (1 lb 12 oz)

Ref.No.	New Parts	Parts No.	Description	Destination
①		B06-0254-08	FRONT GRILLE	E
①		B06-0255-08	FRONT GRILLE	T
		E30-1181-08	SPEAKER CORD SET	
		N99-1044-08	SCREW SET	
②	*	T15-0089-08	SPEAKER	E
②	*	T15-0093-08	SPEAKER	T